

STRUCTURAL NOTES:

- CODE:** Comply with the 2018 International Residential Building Code.
- DESIGN LOADS:**
Dead Loads: Roof = 15.0 psf., Floor = 10.0 psf.
Live Loads: Roof = 45.0 psf (Plus Drift), 2nd Floor = 40.0 psf.
Wind Load: Building = 31.0 psf
- FOUNDATIONS:**
- Bear footings on firm, undisturbed dense native soil at 4'-0" minimum below lowest adjacent finish or natural grade, which ever is lower. Step footings to achieve these depths as required. If stone ledge is encountered place footing directly on ledge where exists.
 - Assumed soil bearing pressure = 2,000 psf.
 - Place foundation concrete on clean, firm, dry bearing material.
 - Engineer shall be notified if ledge or marine clay is found during excavation.
 - Place concrete slab over a 15 mil vapor barrier (taped and sealed at all joints) and locate over stone fill and drainage piping.
 - Install 4" dia. perforated drain tile (rotate perforations to top of pipe) on exterior and interior of footing perimeter. Wrap all drain tile in filter fabric and encase with 3/4" crushed stone around entire pipe. Create a positive drain to atmosphere or dry well with drainage away from structure. Provide (2) stubs through slab for possible use in radon mitigation system. See contractor for mitigation system requirements. Contractor shall be responsible for any additional drainage requirements, such as sump pumps etc.
 - All foundation wall exteriors shall be coated with damp proofing per manufacturer's spec. Damp proofing shall not be visible above final grade.
 - See architectural drawings for additional information not shown.

- CONCRETE:**
- Concrete regular weight (144 pcf) with Type II cement per ASTM C150, aggregate per ASTM C33, and potable water. No fly-ash permitted in floor slab. Aggregate size = 1" maximum for footings and slab. Minimum compressive strength = 3000 psi for foundations and slab on grade and 4,000 psi for exterior slabs and sidewalks.
 - Saw cuts for floor slab control joints (CJ) shall be made as soon as the slab can support the weight of the saw, but no more than 12 hours after placing concrete.
- REINFORCING:**
- ASTM A 615-S1, Grade 60 except #2 and #3 bars ASTM A615-S1: Grade 40.
 - Lap splices in concrete: 42 bar diameters.
 - Provide bent corner reinforcing to match and lap with horizontal reinforcing at corners and intersections of walls, and footings.
 - Reinforcing shall be placed with 3" clearance at all surfaces.

- STEEL:**
- Rolled sections and plates: ASTM A-36, Fy = 36 ksi.
 - Steel Lally Columns: ASTM A513, Fy = 32 ksi. 16 gage steel filled w/ 3,000 psi concrete.
 - Steel Pipe Column: (not lally columns) ASTM A-36, Fy = 36 ksi.
 - Bolts and plain anchors: ASTM A 307, **WOOD:**
- 1. General:**
- Each piece of lumber shall be "S-DRY" and bear the grade stamp of a grading rules agency approved by the American Lumber Standards Committee.
 - Double up studs at jacks and under beams.
 - Do not notch or drill joists, beams or load bearing studs without approval.
- 2. Connections:**
- Nail roof plywood with 8d common at 6" o.c. at all edges and boundary members and 10" o.c. at intermediate supports.
 - Glue floor plywood to all framing members and nail with 8d common at 6" o.c. at all plywood edges and boundary members and 10" o.c. at intermediate supports.
 - Nail CDX wall plywood with 10d common nails at 6" o.c. at all edges and boundary members and 12" o.c. at intermediate supports.
 - Nail Advantech R-6 wall sheathing with 0.131" Dia. x 3" common nails at 3" o.c. along all panel edges and 6" o.c. along intermediate supports.
- 3. Structural Saw Lumber:**
- 2 x 6 thru 2 x 14 joists: Spruce Pine Fir No. 2 with Fb (repetitive) = 1200 p.s.i.
 - Heavy Timbers Beams/Purlins: (unless noted on plan) Eastern White Pine No. 1 with Fb = 875 psi, Fv = 125.0 psi, E = 1,100 ksi.
 - Heavy Timbers Beam: Douglas-Fir No. 1 with Fb = 1,300 psi, Fv = 170.0 psi, E = 1,600 ksi.
 - Heavy Timber Posts: Eastern White Pine No. 1 with Fb = 800 psi, Fc = 625 psi, E = 1,100 ksi.
 - Timber Pegs: 1" Diameter White Oak No. 1.
 - Studs: Spruce Pine Fir No. 1 with Fb (repetitive) = 1200 p.s.i.
- 4. Laminated Veneer Lumber (LVL):** Beams: Fb = 2,600 psi, Fv = 285 psi, E = 2,000 ksi
Posts: Fb = 2,400 psi, Fv = 190 psi, E = 1,800 ksi
Parallel Strand Lumber (PSL): Beams: Fb = 2,900 psi, Fv = 290 psi, E = 2,000 ksi
- 5. Plywood:**
- Roof Sheathing: C-D INT-APA (PSI-94) with exterior glue; 5/8" with Identification Index 48/24. Lay up with face grain perpendicular to supports. Stagger joints. Each plywood piece to be continuous over a minimum of two spans with a minimum width of 1'-0" unless blocking is provided at all joints.
 - Sub-flooring: C-D INT-APA (PSI-94) with exterior glue; 3/4" with Identification Index 48/24. Lay up with face grain perpendicular to supports. Stagger joints. Each plywood piece to be continuous over a minimum of two spans with a minimum width of 1'-0" unless blocking is provided at all joints.
 - Wall Sheathing: C-D INT-APA (PSI-74) with exterior glue; 1/2" CDX with Identification Index 24/0. All panel edges backed with 2" nominal or wider framing.
 - Optional: Advantech R-6 Zip System, 7/16" OSB sheathing with 1" of foam. All panel edges backed with 2" nominal or wider framing.

- SUPPLEMENTARY NOTES:**
- Verify all dimensions and conditions with architectural drawings prior to starting work. Notify the Engineer of any discrepancies or inconsistencies.
 - Provide all necessary temporary bracing, shoring, guying or other means to avoid excessive stresses and to hold structural elements in place during construction.

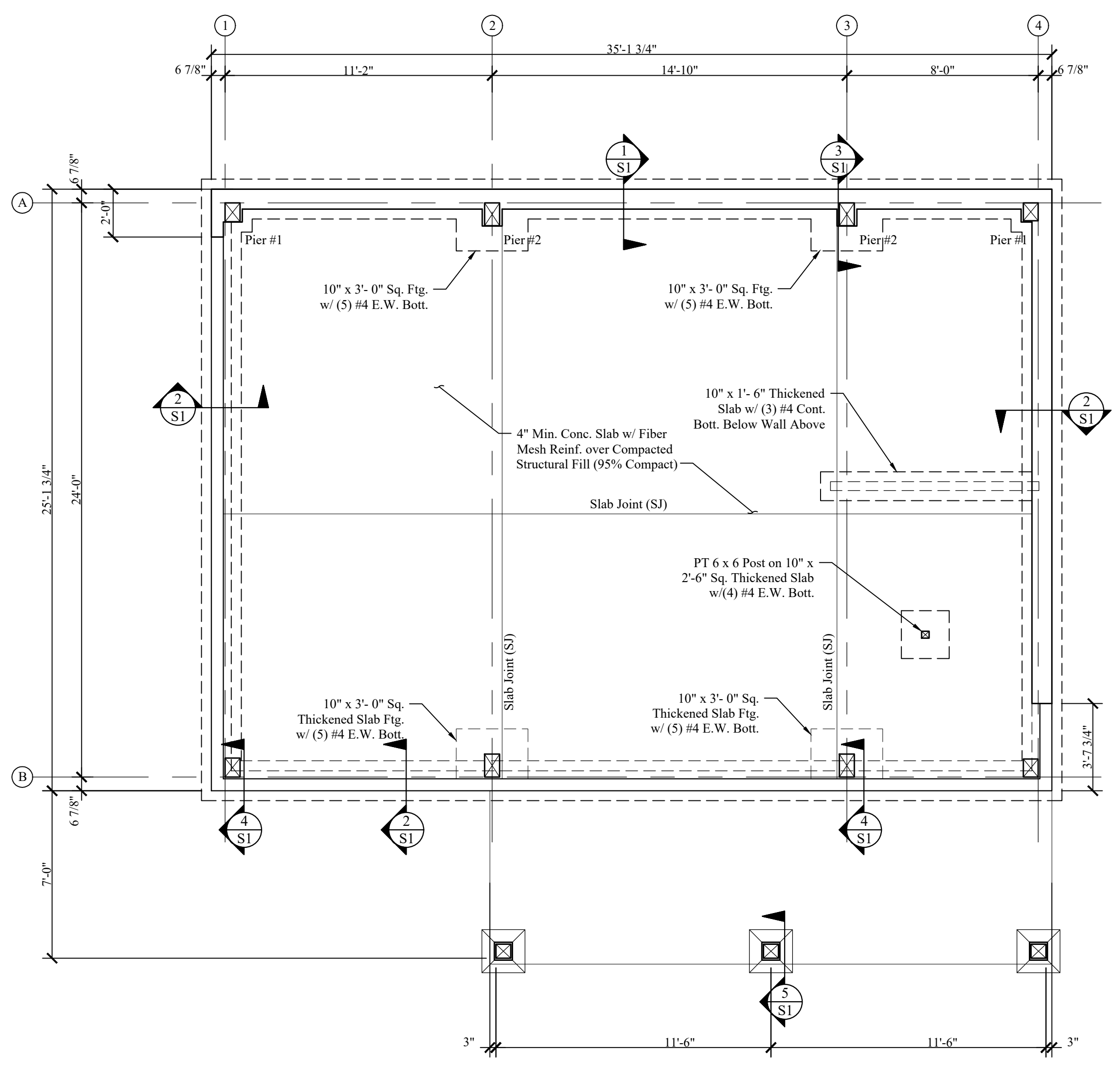

- FOUNDATION NOTES:**
- See General Structural Notes on Sheet S-1.
 - Verify all wall heights and dimensions with architectural drawings prior to commencing work. Notify engineer of any discrepancies.
 - Step footing in field to obtain minimum frost depth.
 - Saw cut concrete floor slab at 12'-0" maximum on center.

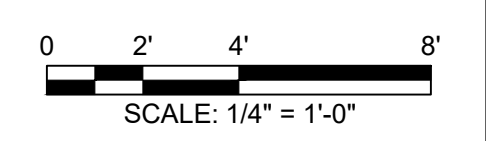

Mechanical, Electrical and Plumbing Design and Building Weatherization-Insulation-Ventilation by Others.

ENGINEERING DESIGN PROFESSIONALS
Consulting Engineers
P.O. BOX 575 • FREEPORT • MAINE 04032 (207) 865-9505

EDP

PROJECT: Dodwell Cottage
Long Island, Maine

DRAWING: **STRUCTURAL NOTES & DETAILS**

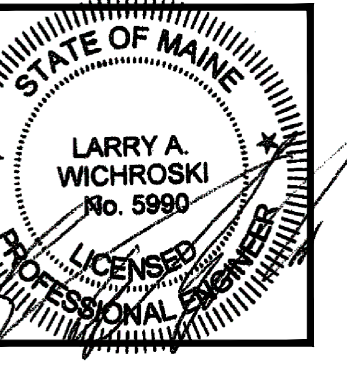

DESIGNED BY: Larry A. Wichroski, P.E.
DRAWN BY: LAW
JOB #: 04422
DATE: 10-28-2022

REVISIONS: 11-28-2022

SHEET: **S1** of 3

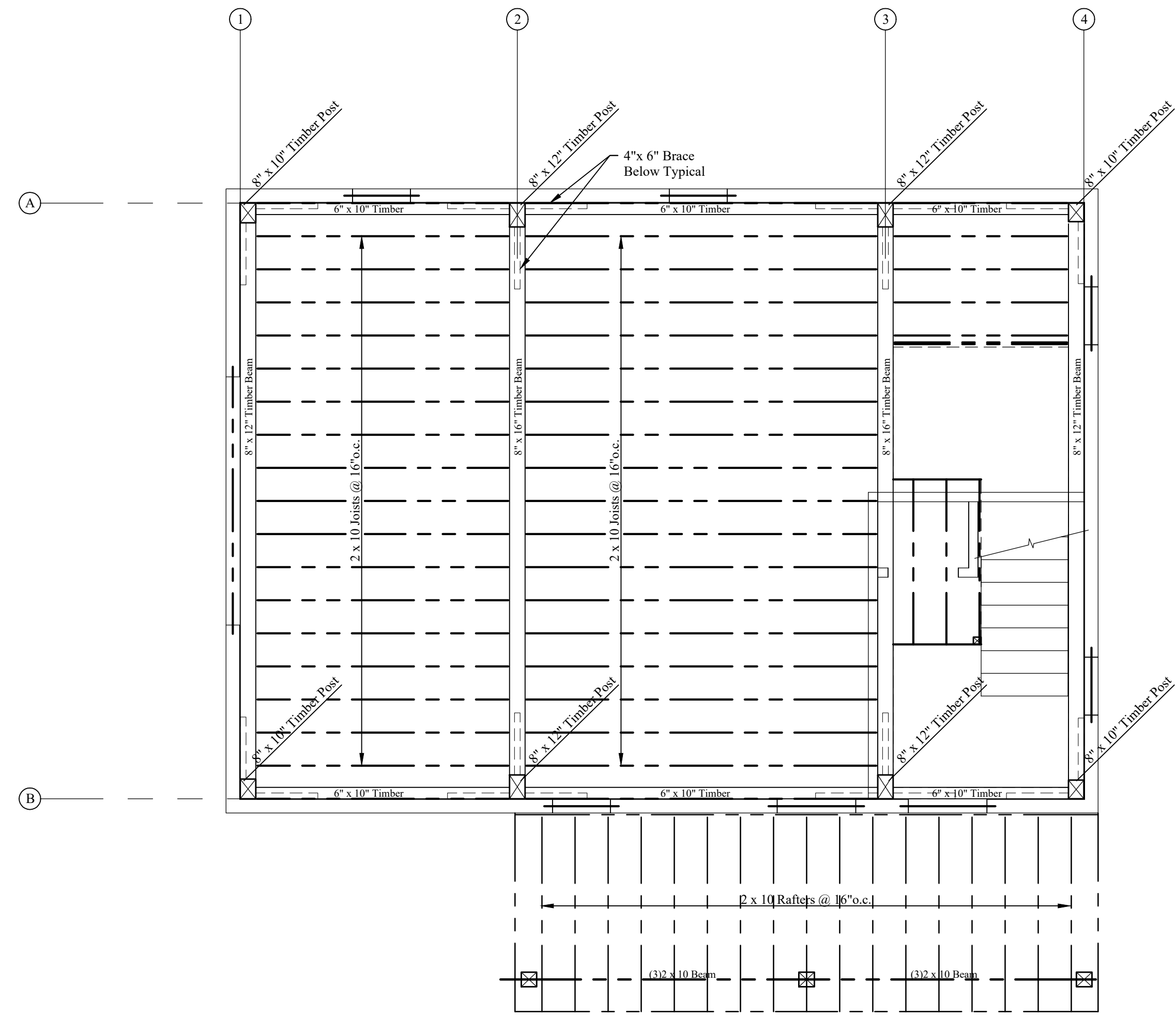

2nd FLOOR & LOW ROOF FRAMING PLAN

Scale: 1/4" = 1'-0"

FLOOR FRAMING NOTES:

1. See Structural Notes, Sheet S-1.
2. Built-up girders, headers and beams shall be spiked w/ 3 rows of 16d nails @ 12" o.c.
3. Provide solid blocking at mid-span of floor joists.
4. See architectural drawings for wall layout and dimensions.
5. Add solid blocking between floor joists below all posts.
6. Connect all porch roof rafters to supporting beam with Simpson H2.5 Seismic & Hurricane Ties per Manufacturer's Instructions.

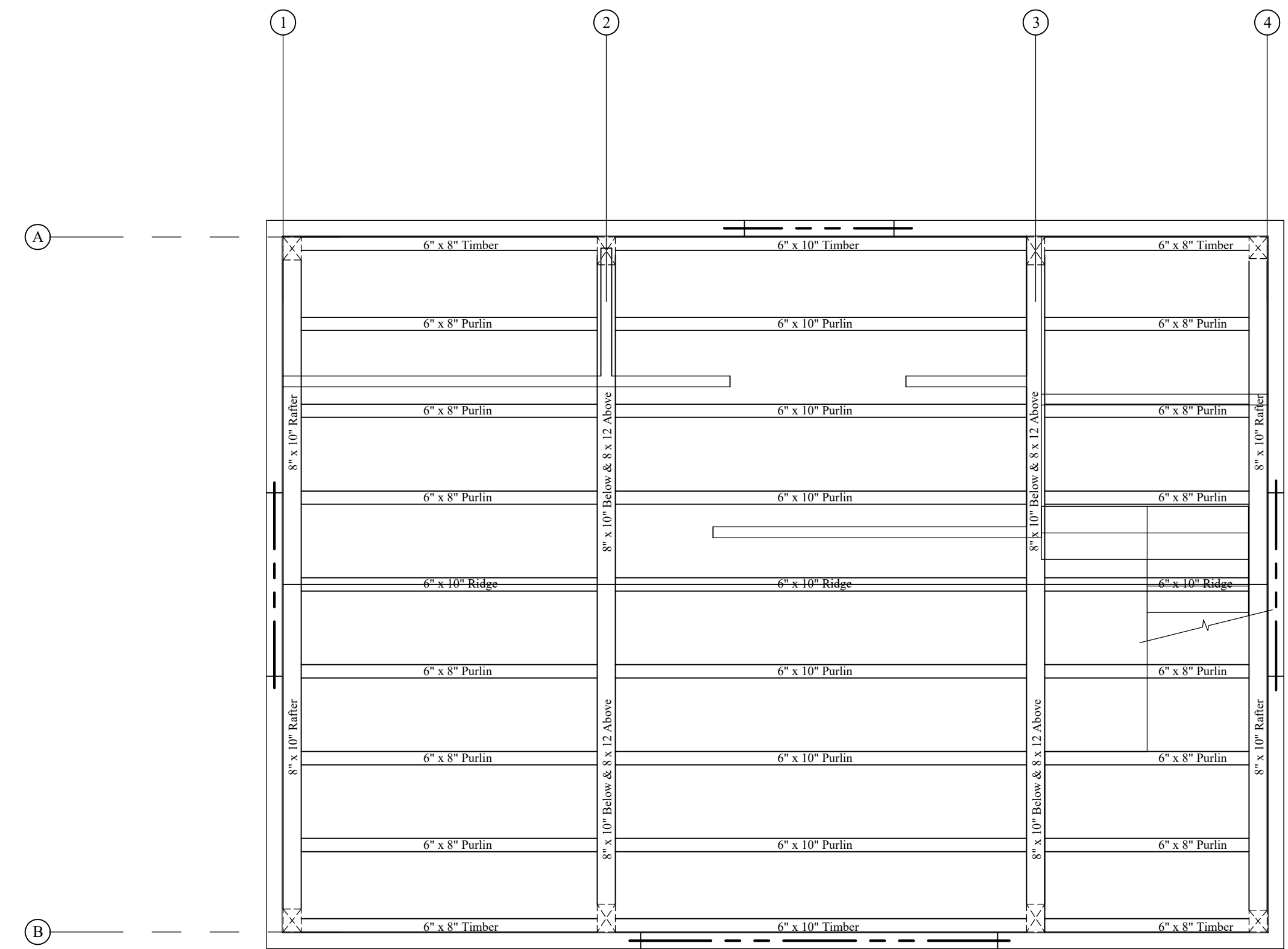

ROOF FRAMING PLAN

Scale: 1/4" = 1'-0"

ROOF FRAMING NOTES:

1. See Structural Notes, Sheet S-1.
2. Built-up headers and beams shall be spiked w/ 3 rows of 16d nails @ 12" o.c.
3. See architectural drawings for wall layout and dimensions.
4. Connect all porch roof rafters to supporting beam with Simpson H2.5 Seismic & Hurricane Ties per Manufacturer's Instructions.

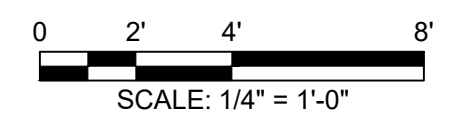

Mechanical, Electrical and Plumbing Design and Building Weatherization-Insulation-Ventilation by Others.



PROJECT:
DRAWING:

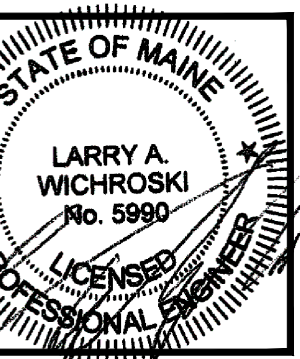

DESIGNED BY:
Larry A. Wichroski, P.E.
DRAWN BY:
LAW
JOB #:
04422
DATE:
10-28-2022

REVISIONS
11-28-2022

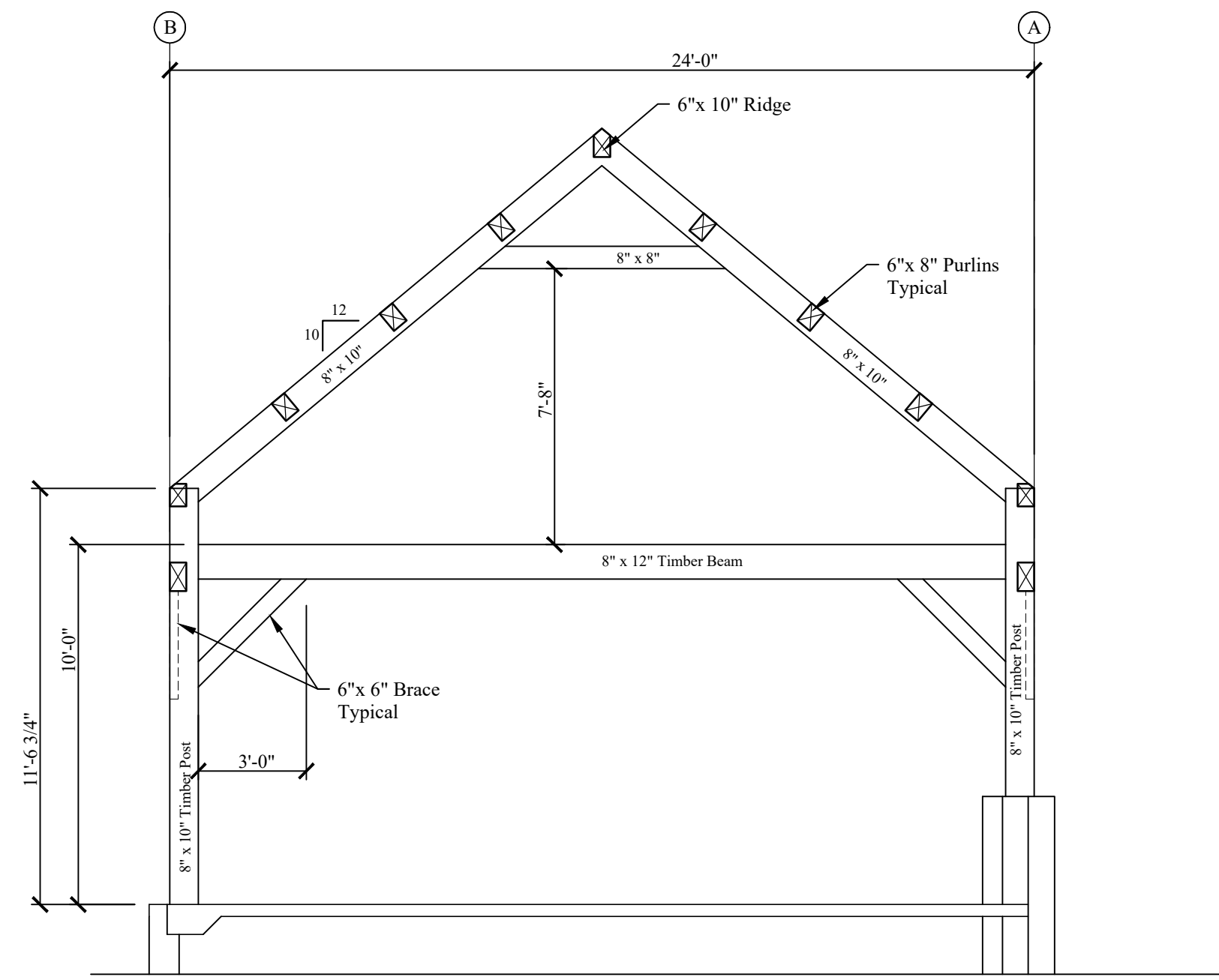

BENT 1 ELEVATION

Scale: 1/4" = 1'-0"

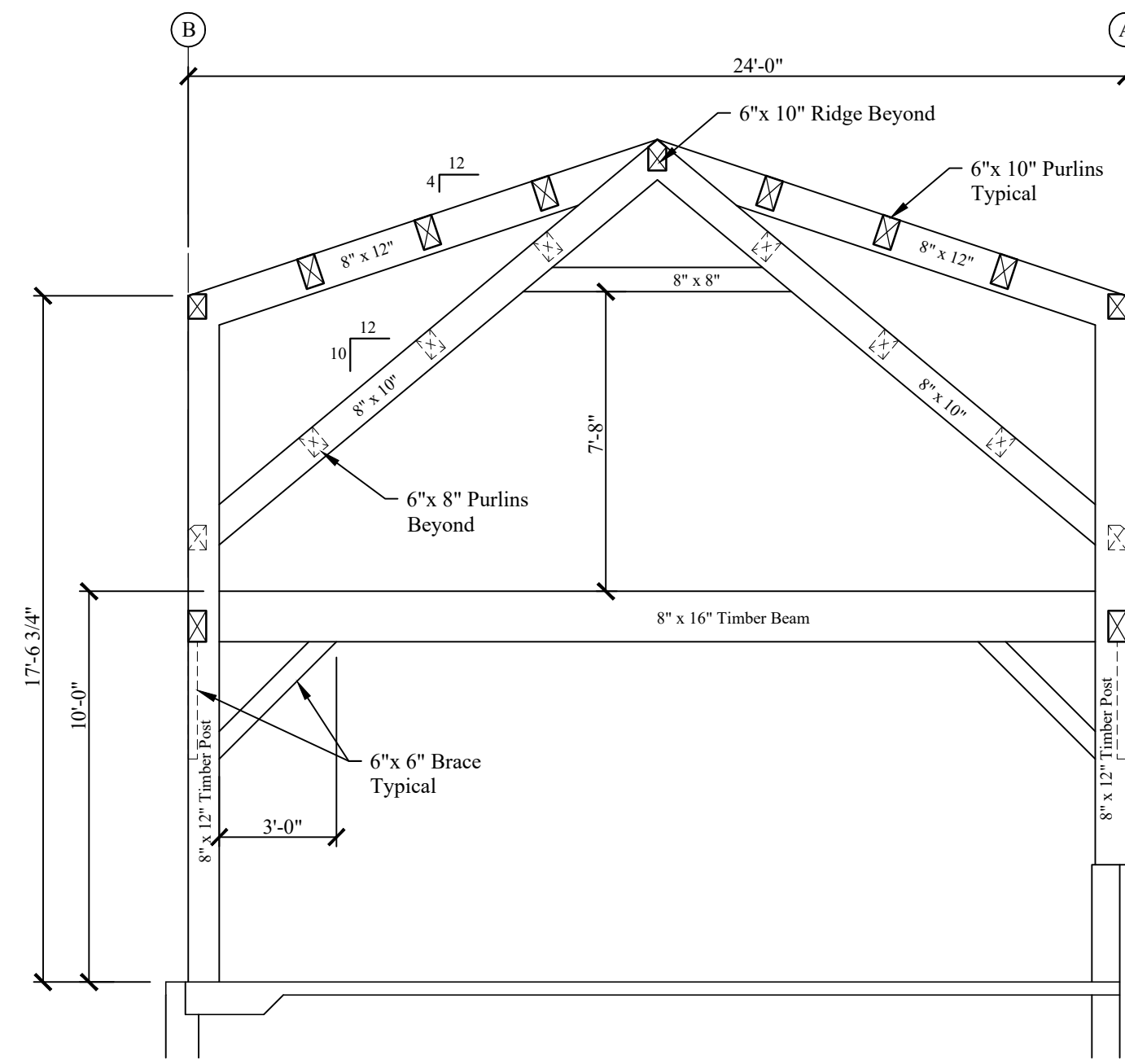

BENT 2 ELEVATION

Scale: 1/4" = 1'-0"

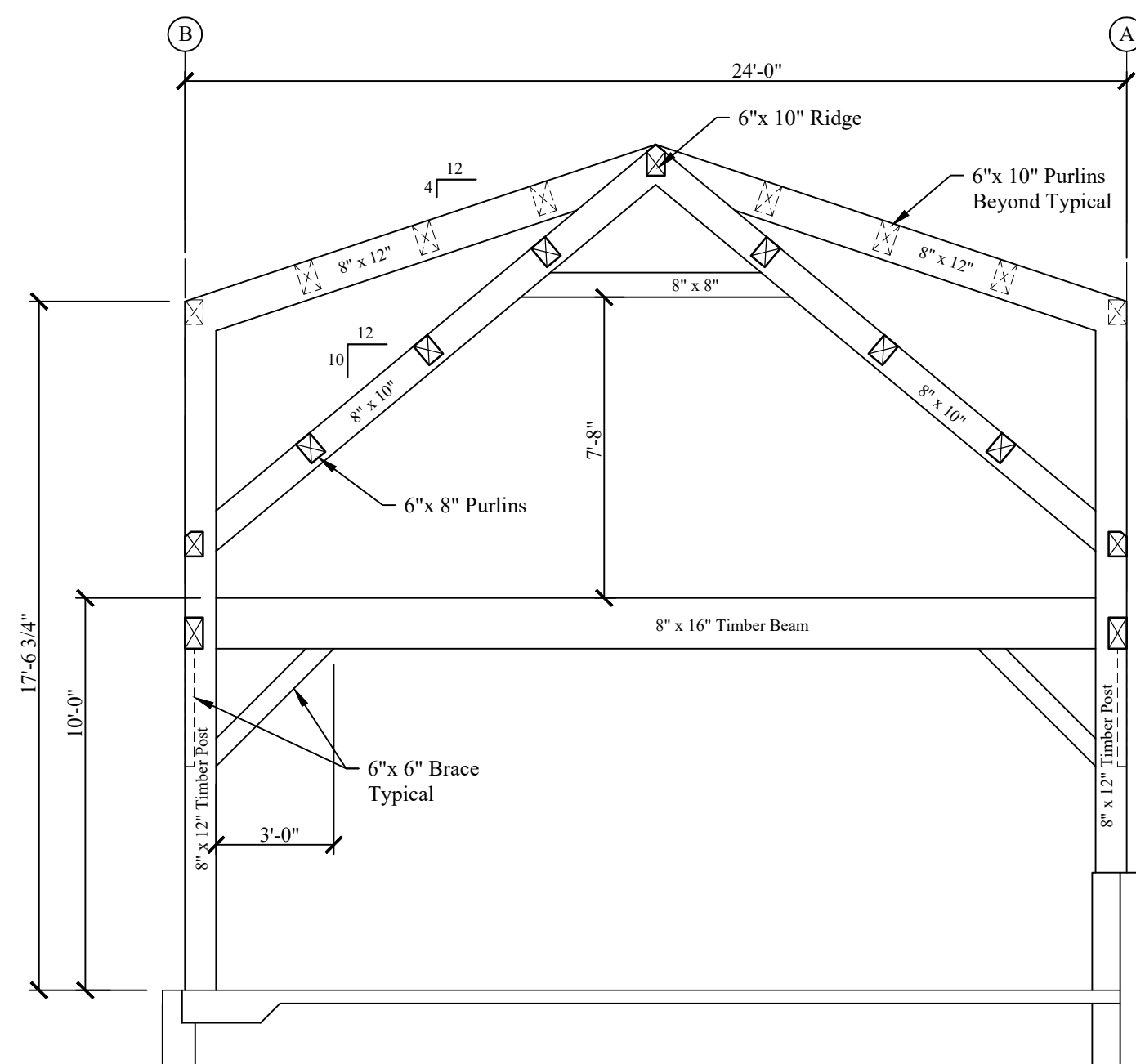

BENT 3 ELEVATION

Scale: 1/4" = 1'-0"

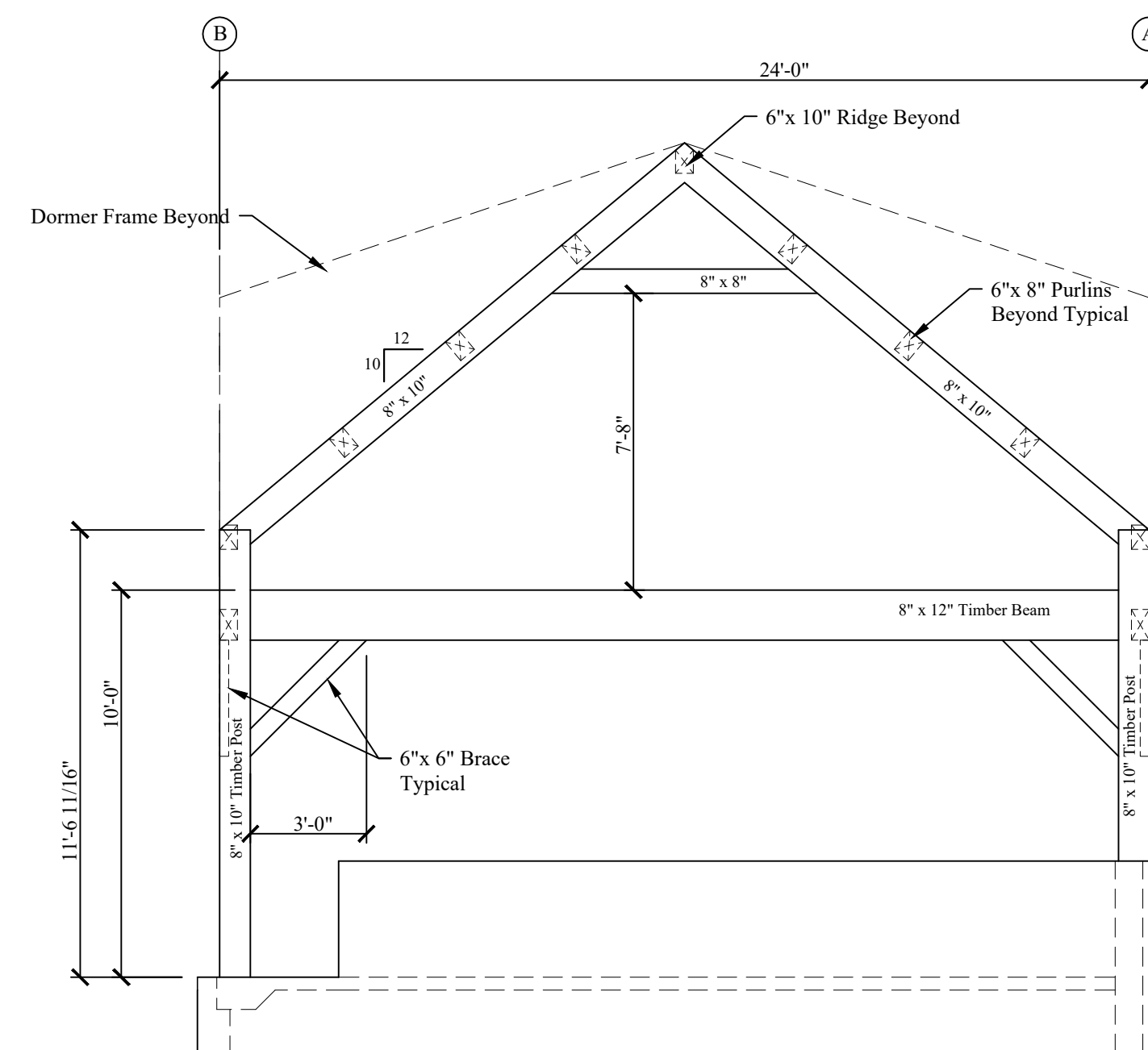

BENT 4 ELEVATION

Scale: 1/4" = 1'-0"

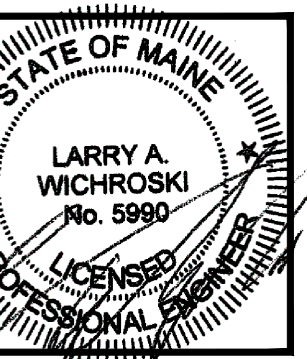
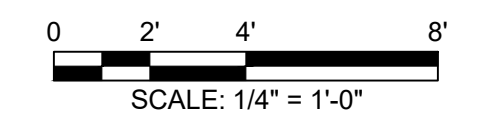

DESIGNED BY:	Larry A. Wichroski, P.E.
DRAWN BY:	LAW
JOB #:	04422
DATE:	10-28-2022

REVISIONS	11-28-2022